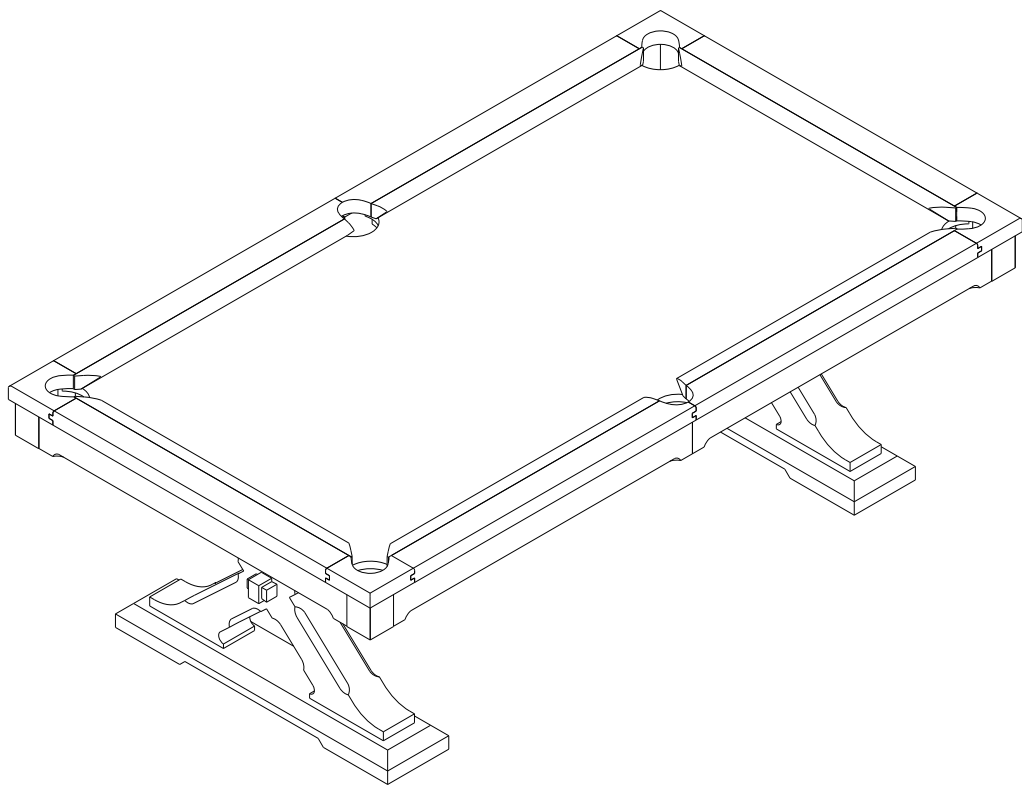




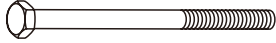


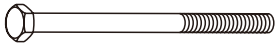













Presidential Billiards, L.P.

# KARIBA








## **KARIBA TABLE ASSEMBLY INSTRUCTIONS**


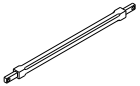

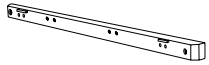

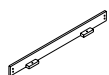
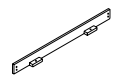
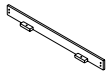






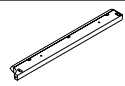
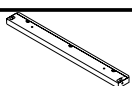
## KARIBA HARDWARE

PACKAGE	ITEM#	SAMPLE	DESCRIPTION	QTY.
<b>LEG/PANEL</b>	H1		<b>HEX HEAD CROSS BOLT</b> 3/8" X 5-1/8"(M10X130mm)	8
	H2		<b>FLAT WASHER</b> 3/8" I.D.	8
	H3		<b>NUT</b> 3/8" I.D.	8
<b>BEAM/BLOCK</b>	H4		<b>HEX BOLT</b> 3/8" X 5-1/8"(M10X130mm)	4
	H5		<b>FLAT WASHER</b> 3/8" I.D.	4
	H6		<b>NUT</b> 3/8" I.D.	4
	H7		<b>HEX HEAD CROSS BOLT</b> 5/16" X 2"(M8X51mm)	4
	H8		<b>FLAT WASHER</b> 5/16" I.D.	4
	H9		<b>HEX HEAD CROSS BOLT</b> 5/16" X 3-1/8"(M8X80mm)	16
	H10		<b>FLAT WASHER</b> 5/16" I.D.	16
<b>RAIL/POCKET/SLATE</b>	H11		<b>FLAT HEAD SCREW</b> 1/4" X 2-3/4"(M6X70mm)	16
	H12		<b>STUD BOLT</b> 5/16" X 5-1/2"(M8X140mm)	2
	H13		<b>STUD BOLT</b> 5/16" X 3-1/2"(M8X88mm)	8
	H14		<b>FLAT WASHER</b> 5/16" I.D.	20
	H15		<b>HEX NUT</b> 5/16" I.D.	20
	H16		<b>HEX HEAD CROSS BOLT</b> 5/16" X 1"(M8X25mm)	24
	H17		<b>FLAT WASHER</b> 5/16" I.D.	24





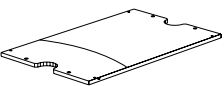
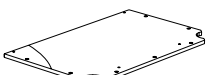

## KARIBA HARDWARE

PACKAGE	ITEM#	SAMPLE	DESCRIPTION	QTY.
RAIL/POCKET/SLATE	H18		<b>HEX HEAD CROSS BOLT 5/16" X 1-7/16"(M8X36mm)</b>	<b>12</b>
	H19		<b>FLAT WASHER 5/16" I.D.</b>	<b>12</b>
	H20		<b>HEX HEAD CROSS BOLT 3/8" X 2-3/8"(M10X60mm)</b>	<b>18</b>
	H21		<b>DOME WASHER 3/8" I.D.</b>	<b>18</b>
	H22		<b>FLAT HEAD SCREW 5# X 1/2"(M3X12mm)</b>	<b>24</b>

## KARIBA COMPONENT PARTS

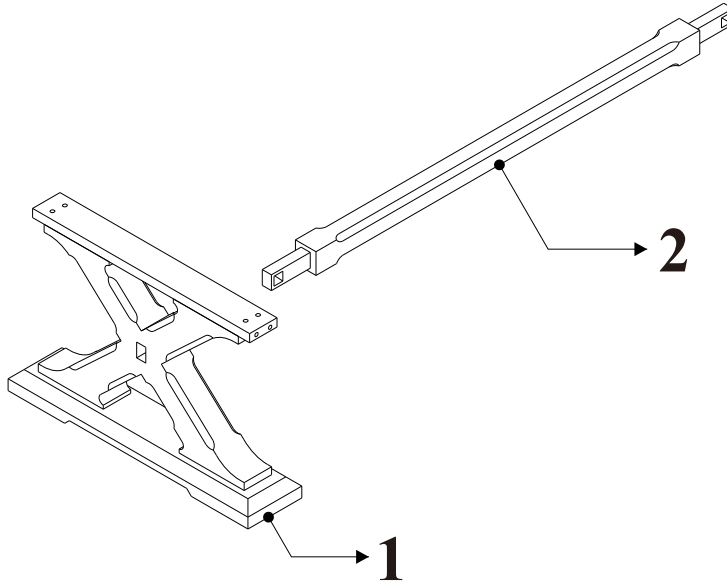
PACKAGE	ITEM#	SAMPLE	DESCRIPTION	QTY.
LEG	1		LEG	2
	2		LEG BEAM	1
	3		WOOD PLUG	2
FRAME(PANEL)	4		SIDE CABINET	2
	5		END CABINET	2
	6		LEFT SIDE APRON	2
	7		RIGHT SIDE APRON	2
	8		END APRON	2
	9		APRON JOINT CONNECTOR BLOCK	2
	10		APRON JOINT CORNER BLOCK	4
	11		LONG WOODEN BLOCK	4
	12		SHORT WOODEN BLOCK	4
	BEAM	13		CROSS BEAM
TOP RAIL	14		TOP RAIL LEFT SIDE	2
	15		TOP RAIL RIGHT SIDE	2
	16		TOP RAIL END	2

## KARIBA COMPONENT PARTS

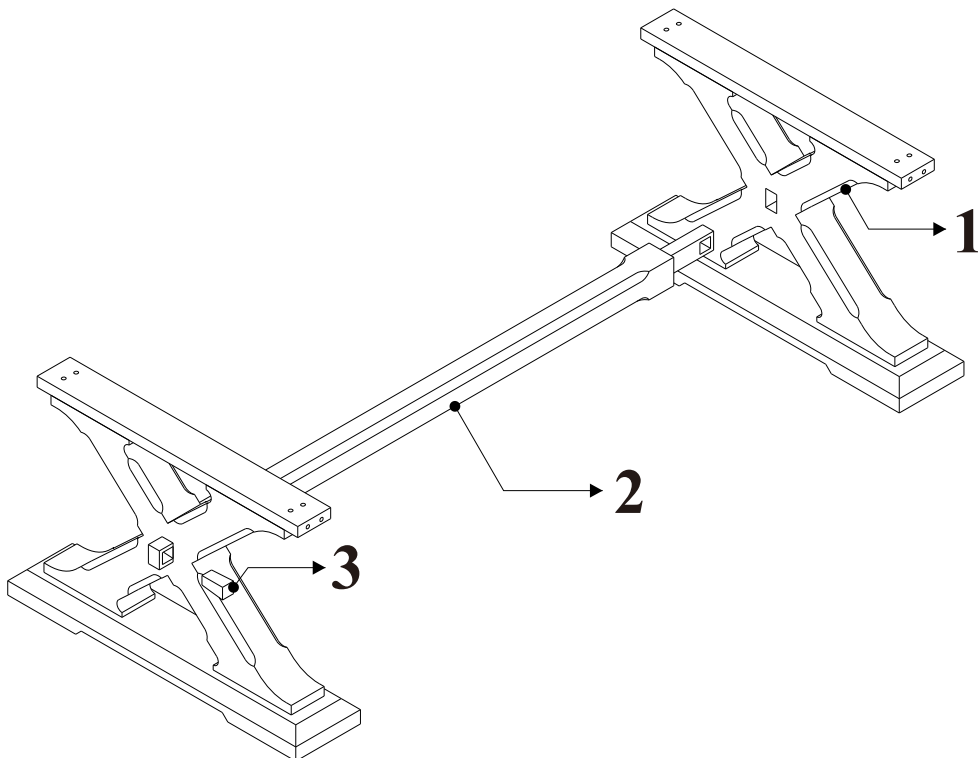
PACKAGE	ITEM#	SAMPLE	DESCRIPTION	QTY.
	17		TOP RAIL CORNER	4
POCKET	18		SIDE POCKET	2
	19		CORNER POCKET	4
SLATE	20		SLATE (LEFT)	1
	21		SLATE (CENTER)	1
	22		SLATE (RIGHT)	1
	23		WOOD JOINT	12

# KARIBA INSTALLATION INSTRUCTIONS

**FIG.1**

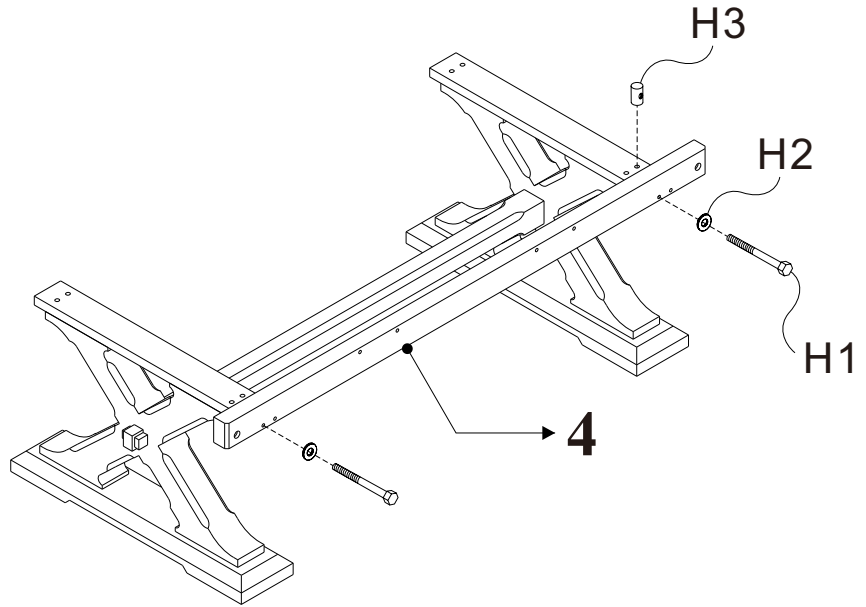


**FIG.2**

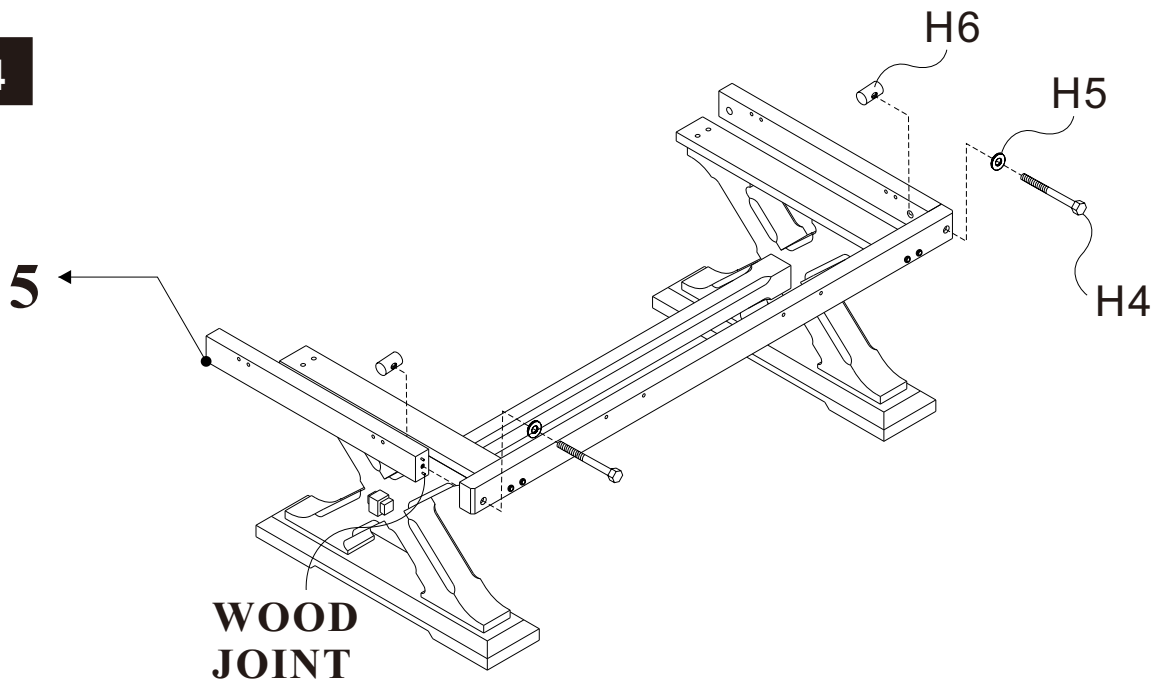


# KARIBA INSTALLATION INSTRUCTIONS

**FIG.3**

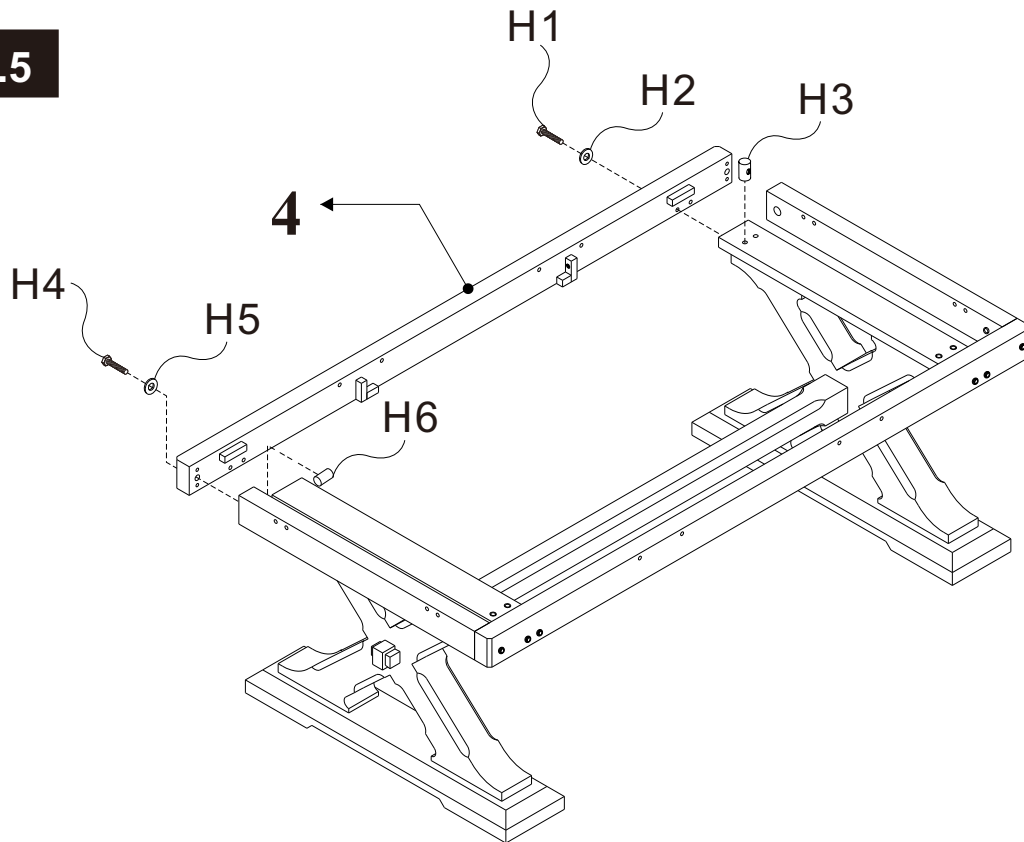


**FIG.4**

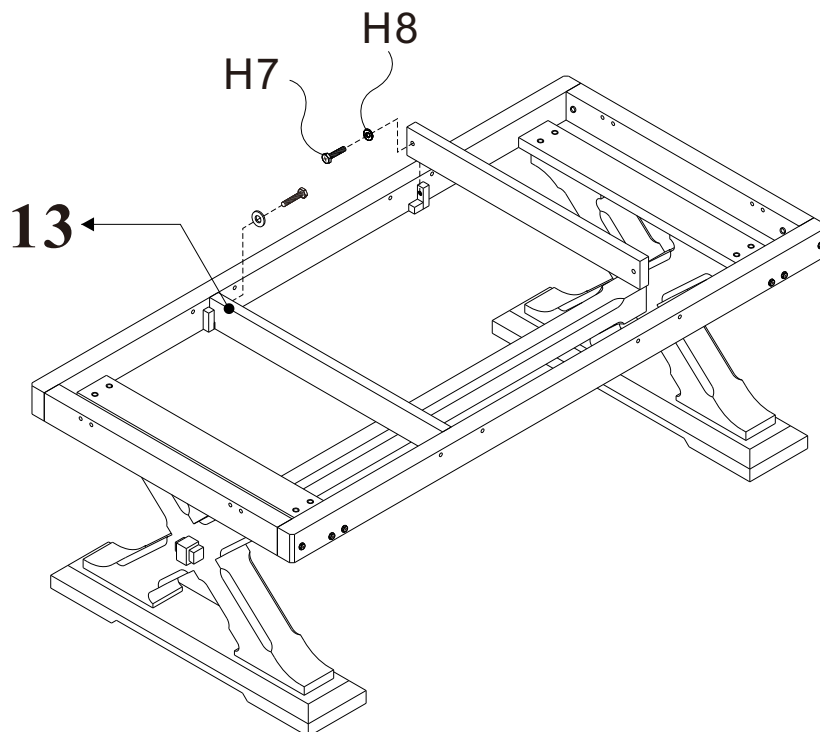


# KARIBA INSTALLATION INSTRUCTIONS

**FIG.5**



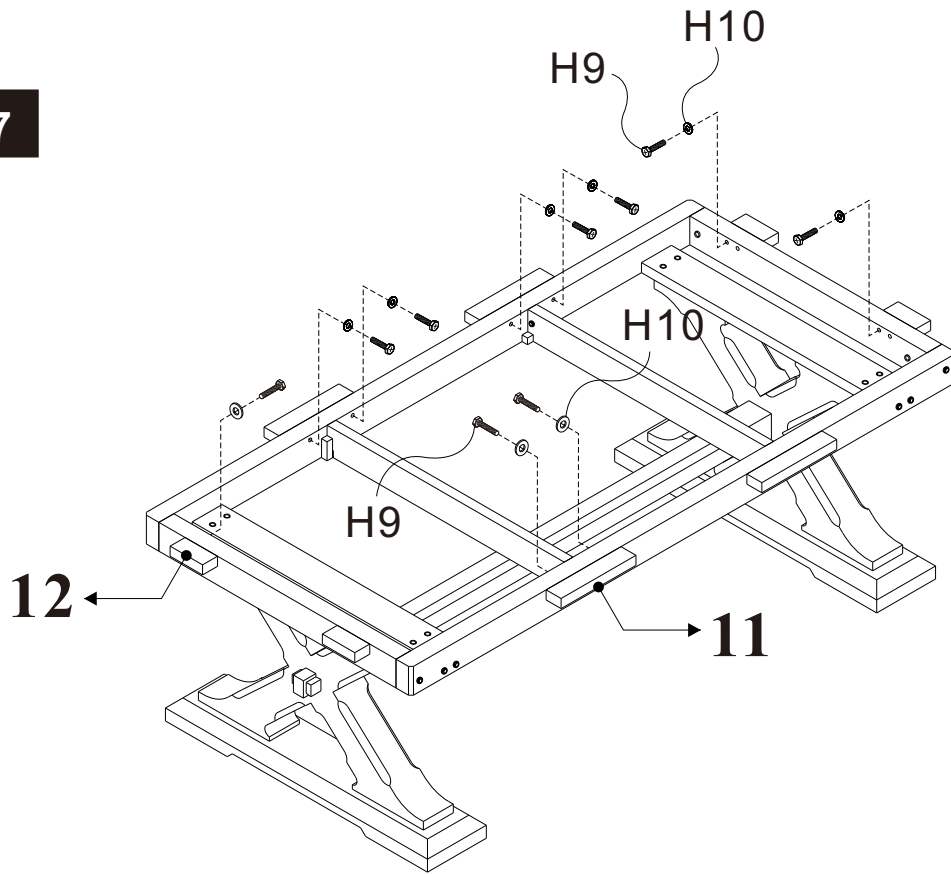
**FIG.6**



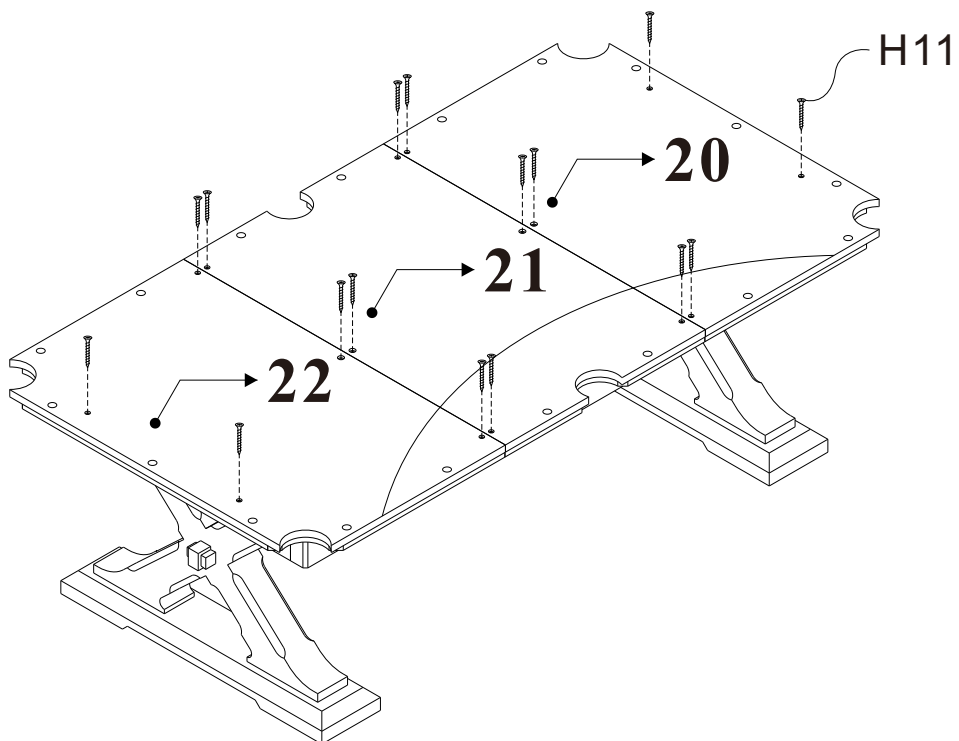


# KARIBA INSTALLATION INSTRUCTIONS

**FIG.7**

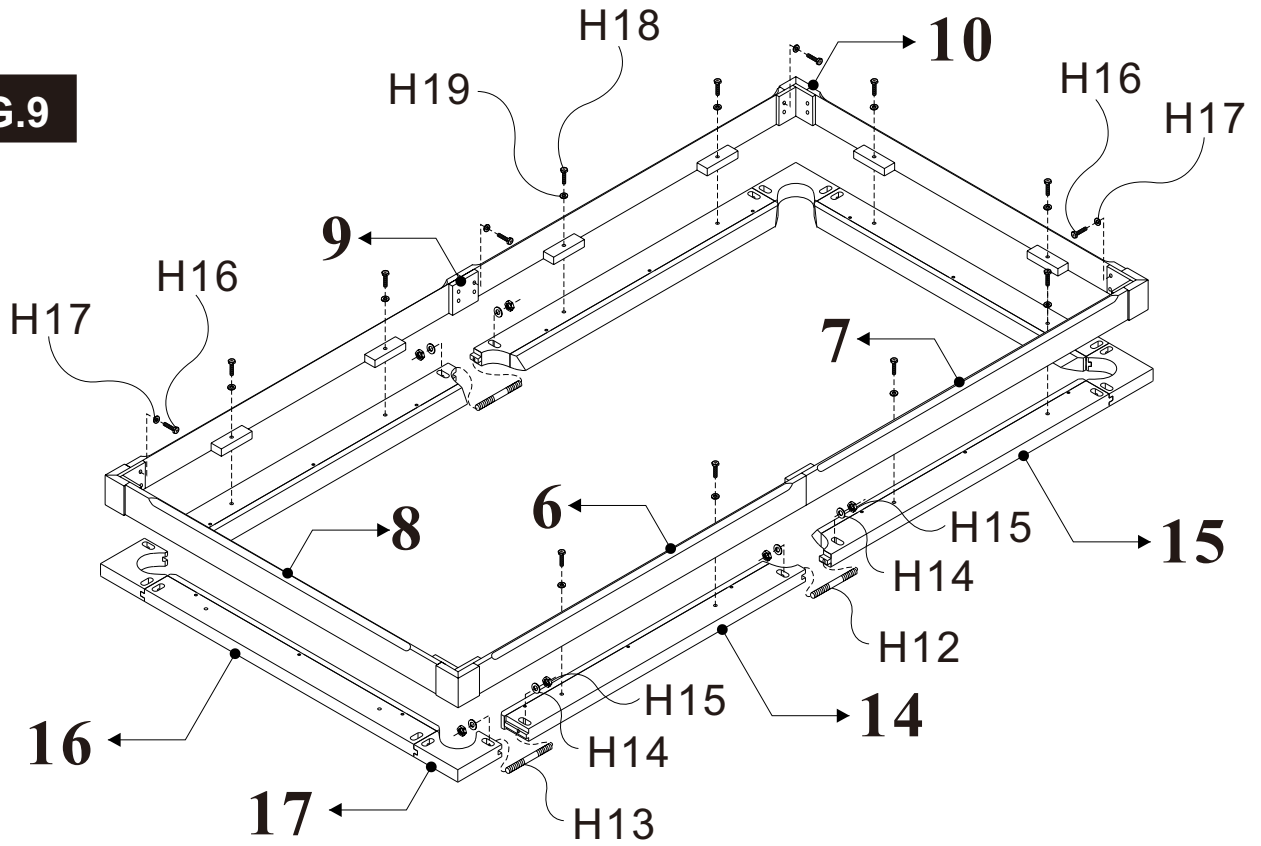


**FIG.8**

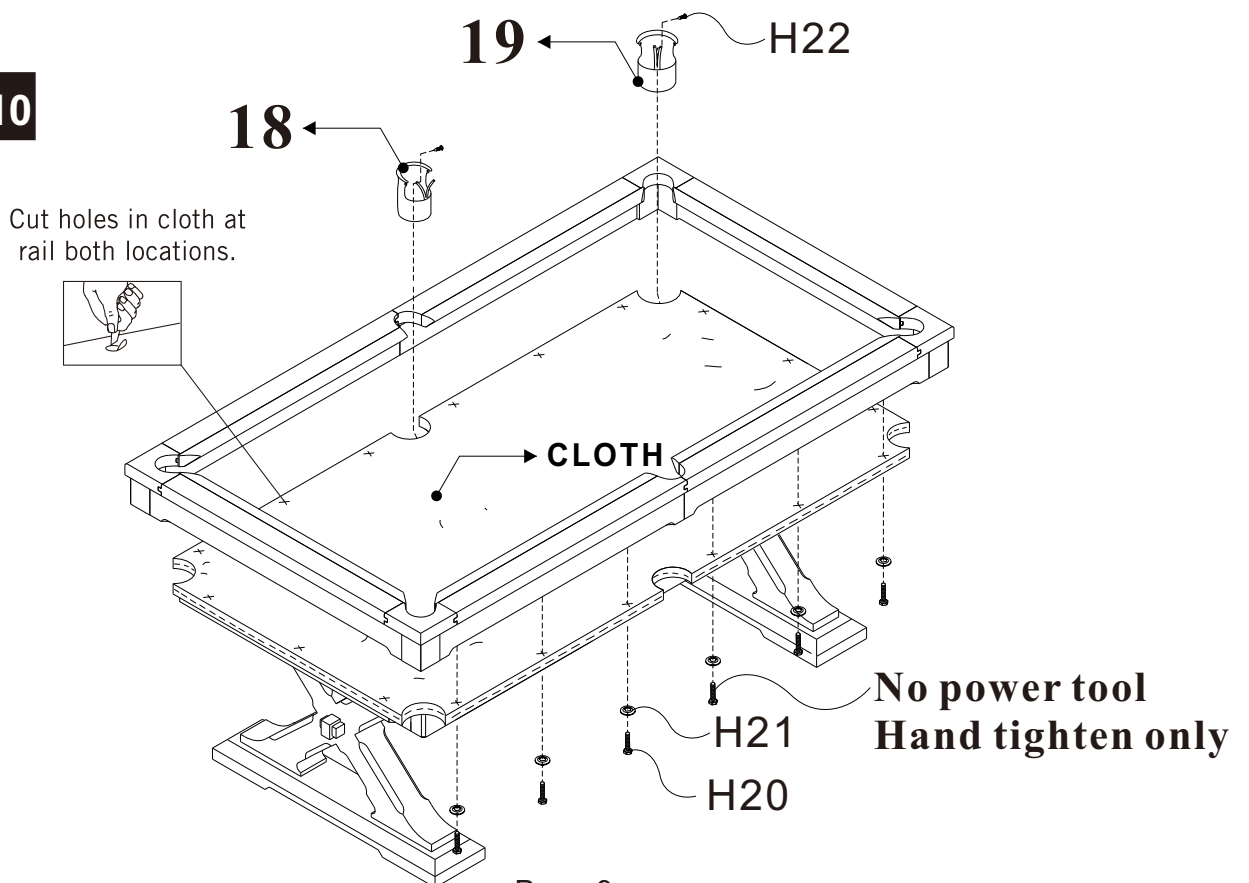


# KARIBA INSTALLATION INSTRUCTIONS

**FIG.9**



**FIG.10**



# KARIBA INSTALLATION INSTRUCTIONS

**Finish**

