

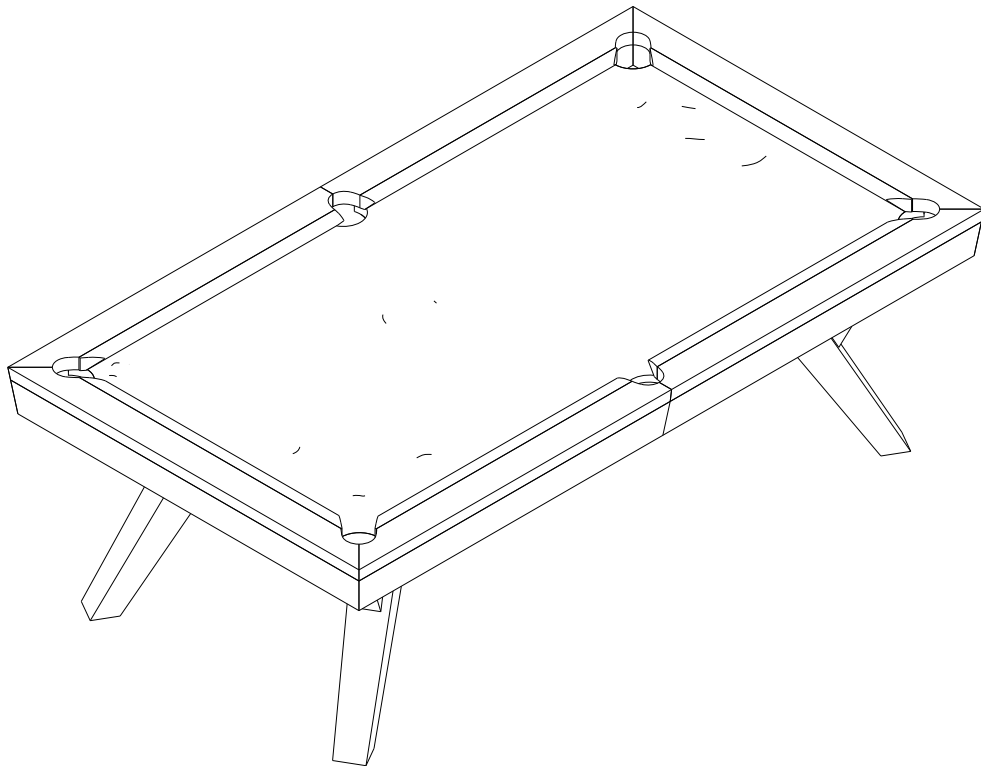















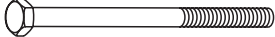

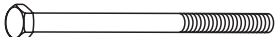
Presidential Billiards, L.P.

TYLER









TYLER TABLE ASSEMBLY INSTRUCTIONS













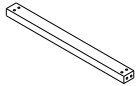
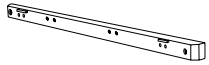
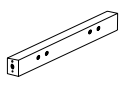

TYLER HARDWARE

PACKAGE	ITEM#	SAMPLE	DESCRIPTION	QTY.
LEG/PANEL	H1		HEX HEAD CROSS BOLT 3/8" X 4-5/16"(M10X110mm)	8
	H2		FLAT WASHER 3/8" I.D.	8
	H3		HEX HEAD CROSS BOLT 3/8" X 3-1/8"(M10X80mm)	8
	H4		FLAT WASHER 3/8" I.D.	8
BEAM/BLOCK	H5		HEX BOLT 3/8" X 5-1/8"(M10X130mm)	8
	H6		FLAT WASHER 3/8" I.D.	8
	H7		NUT 3/8" I.D.	8
	H8		HEX BOLT 3/8" X 5-1/8"(M10X130mm)	4
	H9		FLAT WASHER 3/8" I.D.	4
	H10		NUT 3/8" I.D.	4
	H11		HEX HEAD CROSS BOLT 5/16" X 2"(M8X51mm)	4
	H12		FLAT WASHER 5/16" I.D.	4
	H13		HEX HEAD CROSS BOLT 5/16" X 3-1/8"(M8X80mm)	16
	H14		FLAT WASHER 5/16" I.D.	16
RAIL/POCKET /SLATE	H15		FLAT HEAD SCREW 1/4" X 2-3/4"(M6X70mm)	16
	H16		STUD BOLT 5/16" X 5-1/2"(M8X140mm)	2
	H17		STUD BOLT 5/16" X 3-1/2"(M8X88mm)	4

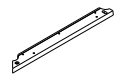
TYLER HARDWARE

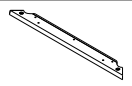
PACKAGE	ITEM#	SAMPLE	DESCRIPTION	QTY.
RAIL/POCKET/SLATE	H18		FLAT WASHER 5/16" I.D.	12
	H19		HEX NUT 5/16" I.D.	12
	H20		HEX HEAD CROSS BOLT 5/16" X 1"(M8X25mm)	24
	H21		FLAT WASHER 5/16" I.D.	24
	H22		HEX HEAD CROSS BOLT 3/8" X 2-3/8"(M10X60mm)	18
	H23		DOME WASHER 3/8" I.D.	18
	H24		FLAT HEAD SCREW 5# X 1/2"(M3X12mm)	24

TYLER COMPONENT PARTS

PACKAGE	ITEM#	SAMPLE	DESCRIPTION	QTY.
LEG	1		L-LEG	2
	2		R-LEG	2
	3		TOP LEG BEAM	2
FRAME(PANEL)	4		SIDE CABINET	2
	5		END CABINET	2
	6		CROSS BEAM	2
	7		LONG WOODEN BLOCK	4
	8		SHORT WOODEN BLOCK	4
	9		APRON JOINT CORNER BLOCK	4
	10		APRON JOINT MIDDLE BLOCK	2
	TOP RAIL	11		TOP RAIL LEFT SIDE
12			TOP RAIL RIGHT SIDE	2
13			TOP RAIL END	2
POCKET	14		SIDE POCKET	2
	15		CORNER POCKET	4
	16		SLATE (LEFT)	1

TYLER INSTALLATION INSTRUCTIONS

FIG.1

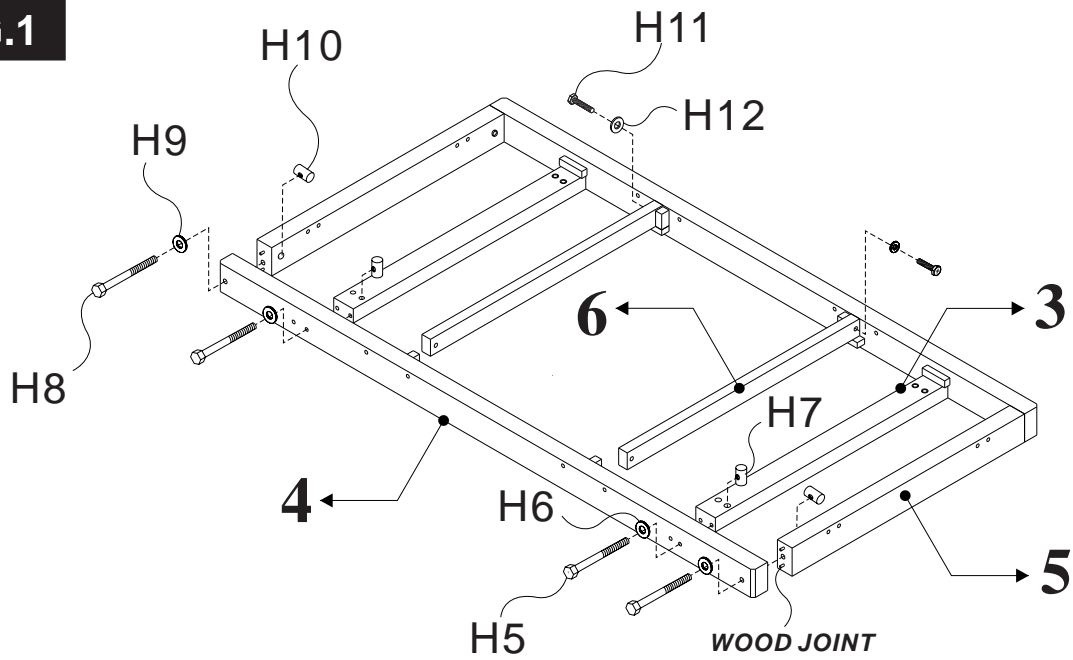
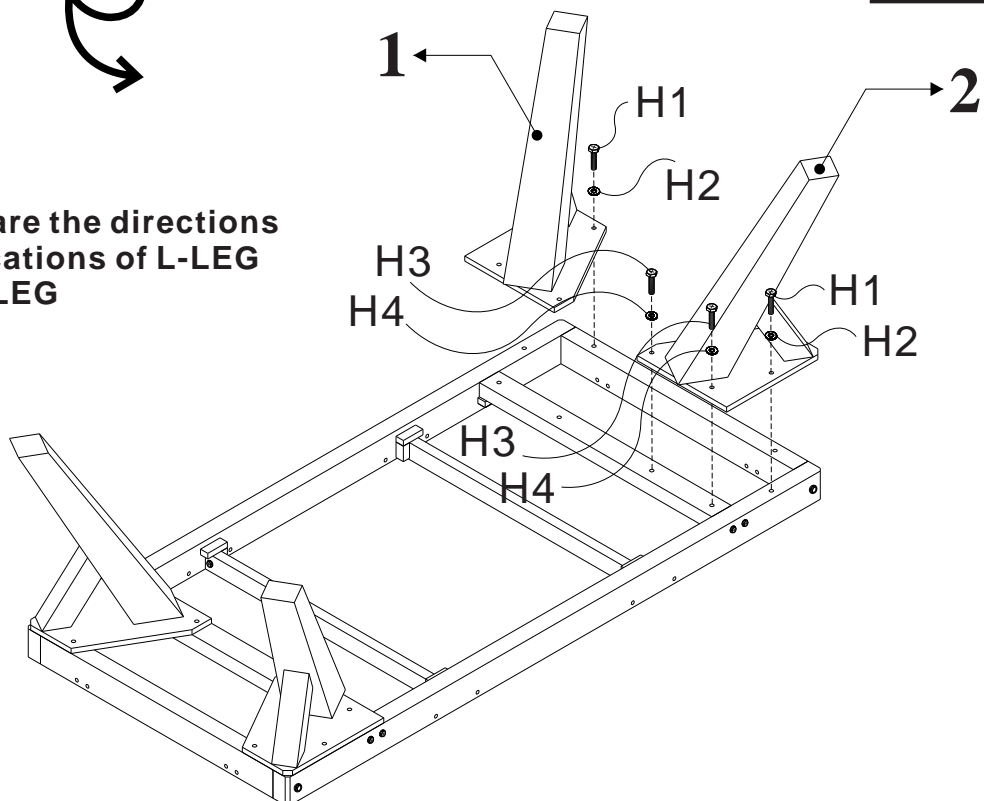

FIG.2

* Be aware the directions and locations of L-LEG and R-LEG



TYLER INSTALLATION INSTRUCTIONS

FIG.3

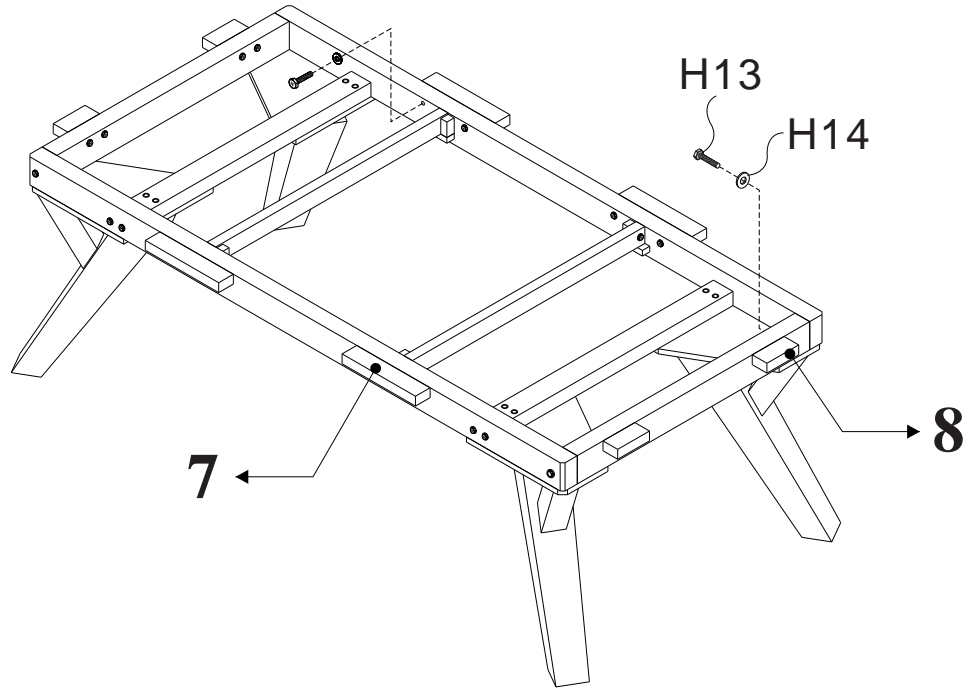
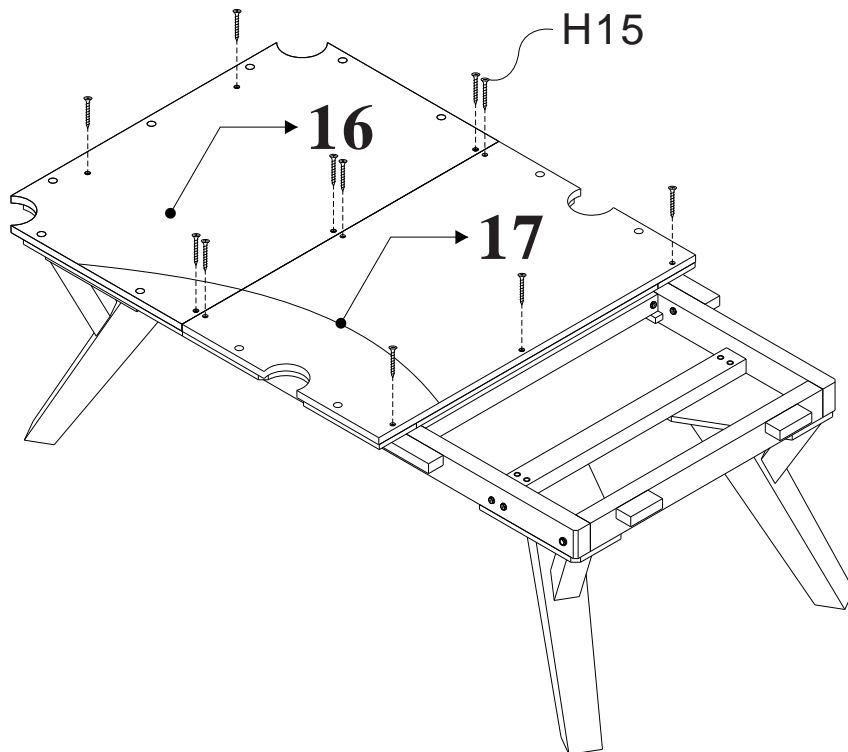

FIG.4



TYLER INSTALLATION INSTRUCTIONS

FIG.5

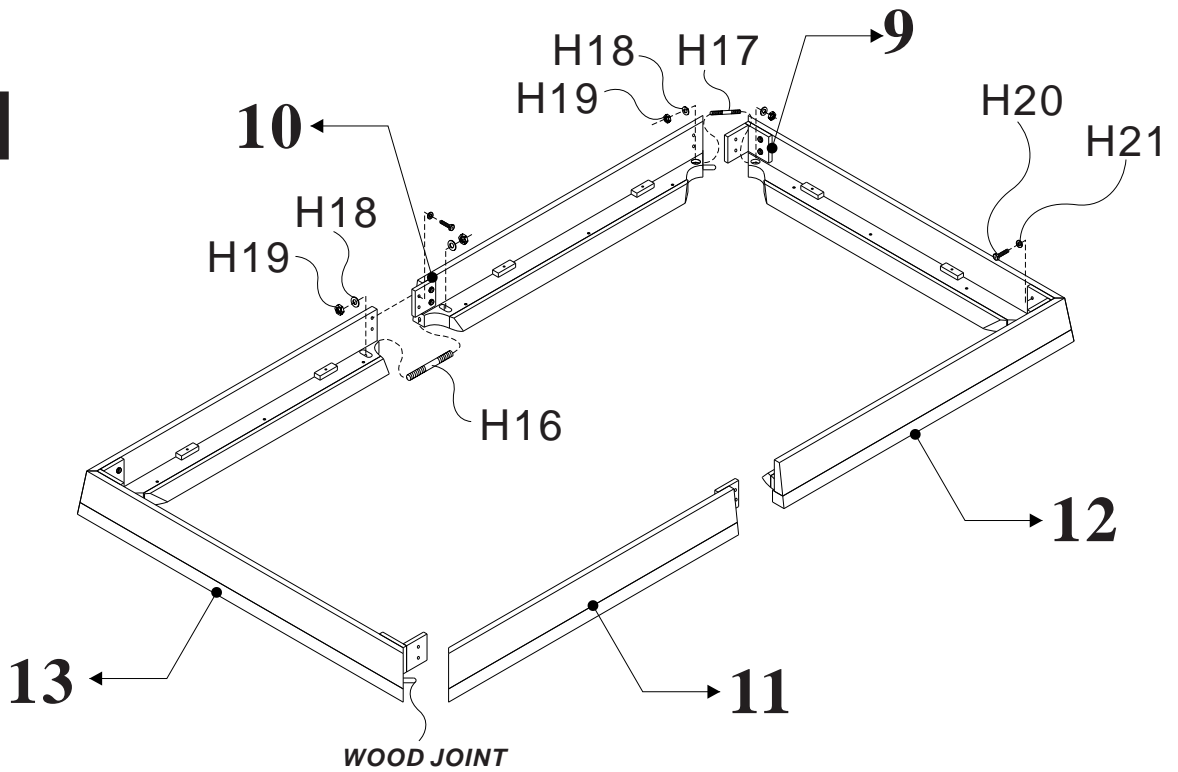
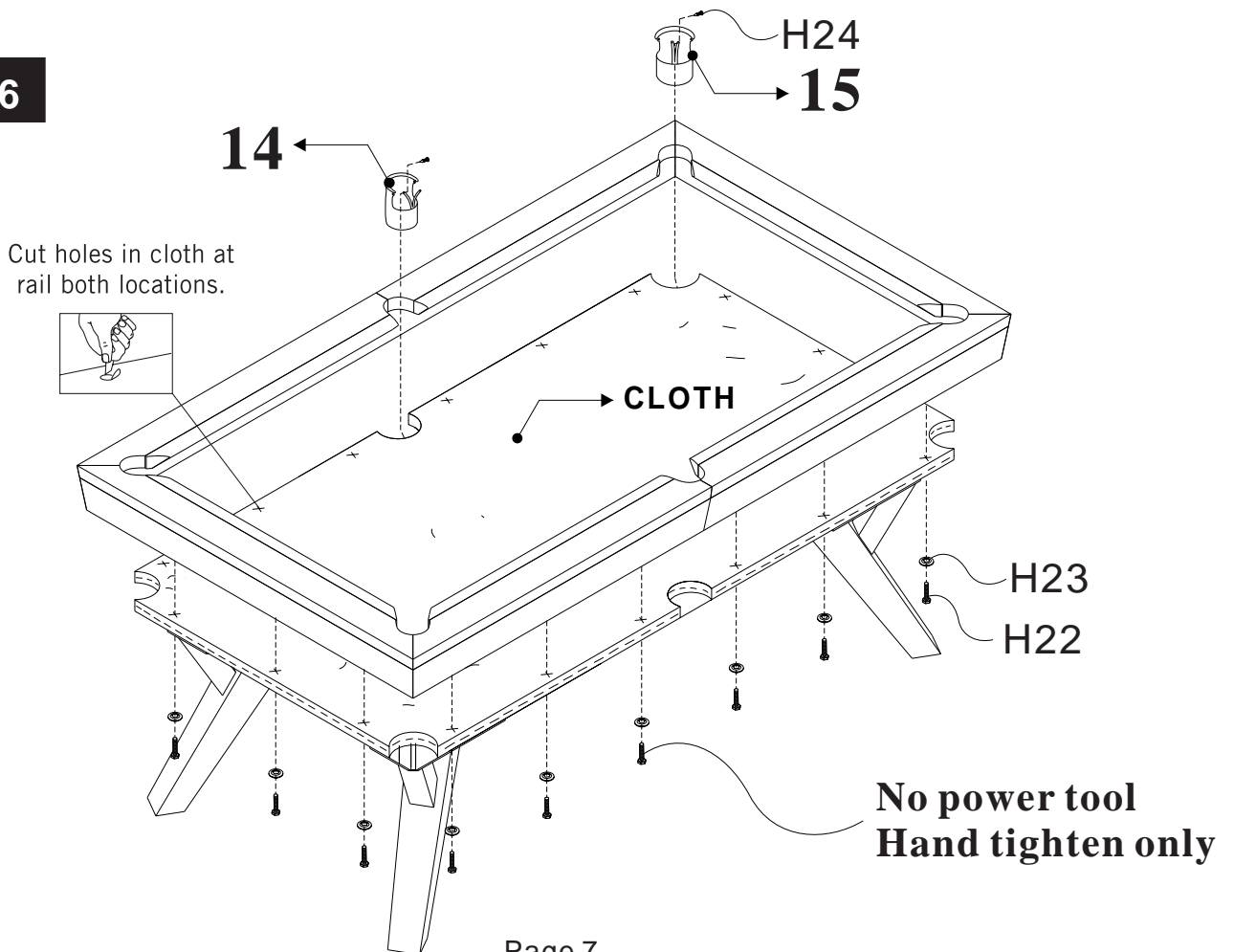

FIG.6



TYLER INSTALLATION INSTRUCTIONS

Finish

